



# HAYWARD GORDON ULC

Pumps • Mixers • Strainers  
Engineered Systems and Controls

---

## Operation and Maintenance Manual

### CHOPX-S and CHOPX-I CHOPPER PUMP Submersible and Immersible

<b>PROJECT:</b>	
<b>EQUIPMENT:</b>	
<b>MODEL:</b>	
<b>QUANTITY:</b>	
<b>SERIAL #:</b>	
<b>LOCAL REPRESENTATIVE:</b>	
<b>DATE:</b>	

FOR INFORMATION, VISIT: [www.haywardgordon.com](http://www.haywardgordon.com)  
FOR SERVICE AND INFORMATION, CONTACT:

**TORONTO**  
Head Office & Plant

5 Bridgen Gate,  
Halton Hills, ON L7G 0A3

Tel: (905)-693-8595

Fax: (905)-693-1452

**MONTREAL**

16755 Hymus Blvd.  
Kirkland, QC H9H 3L4

(514)-697-6445

(514)-697-1164

**CALGARY**

#8 6143-4<sup>th</sup> St. SE,  
Calgary, AB T2H 2H9

(403)-253-2737

(403)-253-1353

**VANCOUVER**  
(US West)

166 Riverside Dr,  
North Vancouver, BC V7H 1T9

(604)-986-8764

(604)-986-8794

Date of Issue: February 3, 2016



### **THE HAYWARD GORDON GUARANTEE**

HAYWARD GORDON ULC endeavours to supply equipment of the highest quality both in materials and workmanship. However, within one year from date of startup or eighteen (18) months from date of shipment (whichever comes first) if any part of the equipment manufactured by HAYWARD GORDON ULC is proven to have been defective in material or workmanship, HAYWARD GORDON ULC shall have the right and obligation to promptly repair or replace such part F.O.B its works. Pumps or parts to be considered for warranty repair or replacement must be returned freight prepaid to Hayward Gordon's factory at Halton Hills, ON. We reserve the right to require the return of defective parts before any claim is recognized.

Materials are certified to be of the specified composition, however, the materials are not guaranteed against chemical attack or wear.

No other warranty or condition, whether statutory or otherwise, is made, intended or to be implied and, except for its obligation to repair or replace defective parts as provided for above, HAYWARD GORDON ULC will not be responsible for any costs or damages, direct or indirect, which may result to the Purchaser from any defect in the equipment (whether of workmanship, material, design or otherwise) or from any breakage or stoppage thereof. Such costs specifically include, but are not limited to, equipment removal, re-installation, and freight. In any event, the liability of HAYWARD GORDON ULC arising through the supply of defective equipment shall not exceed the purchase price of the equipment.

For equipment included in this unit but manufactured by others, HAYWARD GORDON ULC will endeavor to assign to the purchaser, the guarantee extended by such manufacturers to HAYWARD GORDON ULC.

No modifications to this guarantee may be extended without the written authorization of a signing officer of HAYWARD GORDON ULC.



**TABLE OF CONTENTS**

- I. **INSTALLATION** .....I-1
  - A. Unloading .....I-1
  - B. Inspection.....I-1
  - C. Storage .....I-2
  - D. Cleaning .....I-2
  - E. Location.....I-2
  - F. Foundation .....I-3
  - G. Mounting .....I-3
  - H. Grouting .....I-3
  - I. Piping.....I-4
  - J. Motor & Wiring.....I-4
  - K. Motor Cable.....I-5
  - L. Diverter Valve and Nozzle (Optional Feature) .....I-5
- II. **OPERATION** .....II-1
  - A. Lifting Pump.....II-1
  - B. Pre-Starting .....II-1
  - C. Lowering Pump.....II-1
  - D. Motor Operating Conditions – Required Submergence .....II-2
  - E. Start-Up .....II-2
  - F. Diverter Valve and Nozzle (Optional Feature) .....II-3
  - G. Necessary Checks.....II-4
  - H. Stopping the pump.....II-4
- III. **TROUBLESHOOTING** .....III-1
  - A. Vibration – Noise .....III-1
  - B. No Discharge Flow .....III-1
  - C. Not Enough Discharge Flow .....III-2
  - D. Speed too Low .....III-2
  - E. High Power Consumption .....III-2
  - F. Moisture detection light illuminated immediately after start-up.....III-3
  - G. Moisture detection light stays illuminated but no problems found with seals or cable cap assembly.....III-3
- IV. **MAINTENANCE** .....IV-1
  - A. Motor.....IV-1
- V. **SERVICE & REPAIR** .....V-1
  - A. Removing Pump .....V-1
  - B. Disassembly of Pump .....V-1
  - C. Disassembly of Motor .....V-1
  - D. Parts Inspection.....V-2
  - E. Reassembly of Motor .....V-2
  - F. Reassembly of Pump .....V-2
  - G. Parts Inventory Guide .....V-4
  - H. Parts Ordering .....V-4
- VI. **DRAWINGS** .....VI-1
- VII. **MOTOR INFORMATION** .....VII-1
  - A. Electrical Connections.....VII-1



## I. INSTALLATION

### CAUTION!

*Before putting pump into service carefully study and adhere to all sections of this manual, as this is necessary for safe and satisfactory operation of your new Hayward Gordon Pump.*

*This pump has components with sharp edges and pinch areas that can cause cuts. Always wear protective gloves when working on or around the pump.*

*Always disconnect electrical power and lock out the motor starter before performing any work on the pump/motor unit. On duplex pumps with alternating relays, both starters must be locked out regardless of which pump is being worked on.*

### IMPORTANT!

*Prior to installation, lift pump so that it is in the vertical position and rotate the impeller by hand, by reaching in through the suction opening. This will help to ensure that the mechanical seals are seated properly.*

## A. Unloading

Care must be taken when unloading pump.

### CAUTION!

*An adequately sized crane or hoist must be used to lift unit.*

*All lifting equipment (i.e., chains, hooks and eyes) must be in accordance with local or federal safety codes.*

*Failure to use approved lifting equipment may result in serious injury.*

## B. Inspection

Inspection should be performed immediately after unloading pump. Examine equipment for broken, cracked, bent or missing parts. Carefully check:

1. Pump Casing
2. Pedestal
3. Motor

Report all damage or loss to the transportation company and Hayward Gordon ULC.



### C. Storage

#### **IMPORTANT!**

*If the equipment is not to be immediately installed and operated, THE FOLLOWING INSTRUCTIONS MUST BE ADHERED TO AS A MINIMUM.*

Consider a unit in storage when:

1. It has been delivered to the jobsite and is awaiting installation.
2. It has been installed but operation has been delayed pending completion of plant construction.
3. There are long periods (30 days or more) between operation cycles.
4. The plant is shut down.

*NOTE: Improper storage could result in product failures or restoration **not** covered by warranty.*

If not operated immediately, store pump vertically in a dry, well ventilated indoor location that is not subject to rapid or wide variations in temperature. Protect from moisture, dirt, dust and pests.

Rotate motor shaft several revolutions every four weeks to prevent corrosion of bearing and seal components.

Keep ends of power cables clean and dry; do not submerge in water or sewage. Doing so will result in permanent damage.

### D. Cleaning

Clean surfaces of suction and discharge flanges before installation.

### E. Location

Allow ample space for installation, maintenance and inspection. Locate pump base directly below sump opening edge to simplify mounting of guide rail bracket.

**F. Foundation**

Using a certified Hayward Gordon ULC Dimensional General Assembly Drawing, check pump dimensions against foundation and piping dimensions to assure fit.

Install four anchors and make sure that they are long enough to accommodate all necessary grouting/leveling nuts etc. **Do not** grout until guide rails connections are made and alignment established.

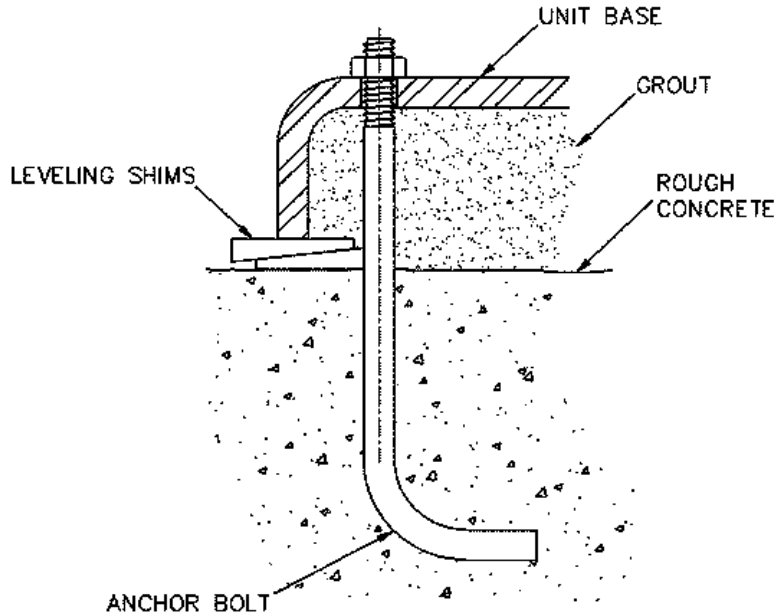

*Figure I-1: Typical Anchor Bolt Detail*

**G. Mounting**

Make sure that pump base is mounted in a horizontal plane. Guide pipes must be vertical and parallel and their top ends held in place with a bracket.

**H. Grouting**

Use of leveling wedges is recommended over leveling nuts. Place wedges as close to foundation bolts as possible and raise unit to desired elevation. Align the unit to the piping. Pack grout from all sides of the base plate until the entire space is filled solid. Allow 48 hours for grout to set. Recheck alignment. Tighten foundation bolts securely if alignment is correct.



## I. Piping

Connecting of piping is done only after grout has set.

1. Remove all foreign objects and debris from the piping (i.e., tools, materials, rags or slag).
2. Independent piping supports should be near the pump to eliminate loads being transferred.

### CAUTION!

*Do not use the pump, discharge elbow or base to support the piping and contents.*

3. Wait until the grout has fully set before connecting the piping.
4. Never draw piping into place by use of force at the flanged suction or discharge connections. The suction and discharge lines should begin at the pump – ending the piping lines at the pump will cause distortion.
5. Provide expansion joints, bends or loops and hangers when handling hot liquids to prevent nozzle loads. A change in temperature of 50 °F will result in a movement of 3/8" in 100 feet of line. Locate discharge side expansion joints after the first pipe anchor to prevent excessive reaction loads on the pump.

### (I) Discharge Piping

Select the size of the discharge pipe so the frictional loss, plus static discharge head, plus working suction lift, does not exceed the total dynamic head on nameplate. Failure to consider the frictional losses will result in power wastage.

Start the discharge pipe at the pump, ending at the final discharge point. Avoid abrupt pipe size changes and use only concentric taper increasers.

Recheck the pump alignment after all the piping is connected.

## J. Motor & Wiring

### CAUTION!

*Submersible pump motors are equipped with moisture detection devices. Failure to properly connect or utilize this system voids the motor warranty.*

See motor instruction manual for wiring, operation and maintenance details.

**K. Motor Cable**

Make sure there is sufficient length of motor cable to accommodate total pump/motor travel from engaged, sump bottom position to service/maintenance position above top sump opening.

Suspend motor cable in a manner preventing it from any possibility of damage or strain during operation, removal or service of pump.

**L. Diverter Valve and Nozzle (Optional Feature)**

Refer to Drawing 026-30263

- Install base elbow on a level surface ensuring the pump's suction to floor clearance is a minimum of that shown on the general arrangement drawing. Locate the base elbow such that the vertical control rods (Item 7&8) will be centered in the base plate (Item 4) to ensure free rotation.
- The diverter valve & recirculation assembly (Item 3) is then mounted on the base elbow with gasket and supplied hardware in the orientation shown on the General Assembly drawing.
- Locate base plate in the approximately the correct location, insert control rods (Item 7, 8 & 9) through appropriate holes in the base plate – refer to General Arrangement drawing. Fix rods in place to diverter valve assembly (Item 3) using cotter & clevis pins. Adjust base plate so that control rods are square and parallel to within 1/8" which will ensure smooth rotation of the control rods. Anchor base plate in final location.
- Connecting automatic actuators: Connect ONE end of the linkage arm to automatic actuator arm. Manually rotate diverter valve control rod (Item 8) to the fully open and fully closed position. Before connecting linkage arm to control rod handle, activate the actuator to ensure movement past either the fully open or fully closed position will not occur. Adjust accordingly and pin in position.





## II. OPERATION

### CAUTION!

*Equipment and lifting devices such as chain, lifting eyes, hooks, etc. must be approved by local or federal safety codes.*

*If pump is supplied with a UL approved quick disconnect, a non-sparking lifting chain or cable is to be used.*

*Hoist and crane must be adequately sized to lift rated loads.*

*Failure to use approved lifting device may result in injury.*

### A. Lifting Pump

The lifting winch shall be mounted directly above motor centre lines so that the lifting cable is parallel to the guide rails while the pump is being raised or lowered into its working position.

Attach lifting chain/cable securely to motor lifting yoke. The chain and lifting yoke shall remain attached to the motor at all times while the pump is lowered or operating in the sump.

The chain hook shall be mounted directly underneath the sump opening cover in order to prevent any accidental chain dropping and possible damage to the pump, should it be drawn into the suction.

### B. Pre-Starting

1. Connect motor as outlined by the motor instructions and make sure that all level controls and switches are properly wired (See Electrical Connections).
2. Pump rotation must be clockwise viewed from motor end. Jog starter switch and observe starting reaction (suspend the pump on chain to perform this test). The reaction should be counter-clockwise viewed from motor end. As an alternative, verify the rotation of the impeller by viewing it from the suction nozzle.

### C. Lowering Pump

Sump bottom shall be clear of all debris and other solid particles.

Lubricate with grease the mating faces of the quick-disconnect device. Sealing of the faces is accomplished by the pump's own weight.

Lift and move pump to a position directly over the guide pipes. The lifting winch shall be mounted directly above motor centerlines so that the lifting cable is parallel to the guide rails while the pump is being raised or lowered into its working position. Lower it slowly until angled flange mount fits correctly around guide pipes, and when engaged, lower it, steadily down until seated on its sump bottom base.

Once pump is in place, fasten the lifting chain to its hook leaving as little slack as possible.

**D. Motor Operating Conditions – Required Submergence****(I) Submersible Motors**

Submersible motors must be fully submerged during operation in order to provide sufficient cooling. The motors are designed to run continuously in water or 15 minutes in air. The water level should be no lower than the top of the motor. Failure to keep the motor submerged will result in motor overheating and possible serious damage.

**(II) Immersible Motors**

Immersible motors are capable of operation either continuous in air or submerged.

**E. Start-Up****CAUTION!**

*Discharge valves must be fully open during start up and operation. Suction and discharge piping must be free of obstructions. Operation of pumps with closed valves and/or clogged piping could cause damage to the pump and is dangerous.*

1. Standard submersible motors must be fully submerged during operation in order to provide sufficient cooling (not required for CLC continuous-in-air designs). Failure to keep the motor submerged will result in motor overheating and possible serious damage.
2. Keep discharge valve fully open.
3. Start pump in manual mode.
4. Run a brief test at different pump flows, recording motor electrical readings, making sure that duty point measurements are within acceptable limits.
5. When satisfied with the above results, switch into automatic mode and cycle the system a number of times through the sump pumpdowns to verify functioning of the level controls and alarms.

**F. Diverter Valve and Nozzle (Optional Feature)**

To ensure smooth operation of controls without binding, the cover plate is to be installed level and with control rod openings concentric to base assembly to within  $\pm 1/8$ "

*Figure II-1: Diverter Valve & Nozzle Controls*

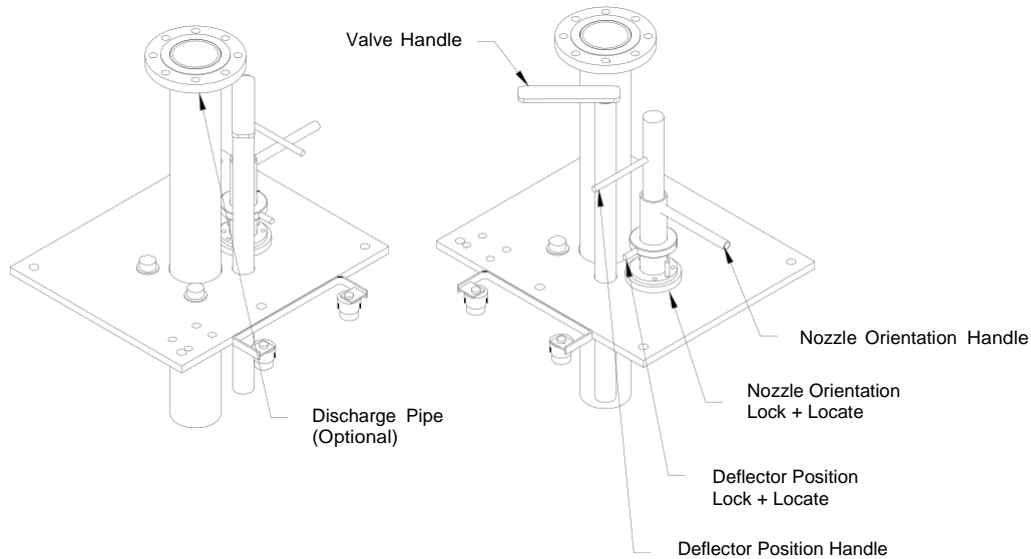

The recirculation nozzle swings a minimum of 180° in the horizontal plane, 70° in the vertical plane, and is operated by handles on the cover plate (see Figure II-1). The diverter valve should be in recirculation mode for a few minutes prior to pump out to ensure scum blankets are incorporated into the pumpage and suspends any solids settled on the pit floor. Swiveling the recirculation nozzle both horizontally and vertically washes material from the pit walls and helps incorporate scum blankets and settled solids.

1. To change direction of the nozzle in the horizontal plane, pull out the pin that locks the sprocket of the nozzle swivel handle and turn the swivel handle. The handle points in the same direction as the nozzle. Re-insert the pin to lock the swivel handle in place.
2. To change the direction of flow in the vertical plane, remove the pin in the nozzle swivel rod. Position the rod up or down to move the nozzle angle vertically – once the desired position is obtained, re-insert the pin through the nearest hole in the control rod.
3. To change from mixing / recirculation mode to discharge mode, turn pump off and pull out the locking pin in the valve control handle. Turn the control handle to the right. Re-insert pin to hold valve position.
4. **Optional Automatic Valve Actuator.** The valve orientation handle may be fitted with an electrically operated actuator for remote control of the valve position between recirculation mode and discharge mode. Below is the wiring diagram for the actuator.



**G. Necessary Checks**

Pump should operate satisfactorily if Hayward Gordon ULC instructions have been followed. However, regular routine maintenance and inspection of the pump performance as well as the condition of its parts is required. Record any performance deviations, which could indicate wear or possible problems.

**H. Stopping the pump**

1. Stop motor.
2. Close discharge valve.
3. Indefinite Shutdown – lock motor starter or disconnect motor cable at control panel and remove pump from sump.

**III. TROUBLESHOOTING**

Hayward Gordon pumps will provide reliable service and long life, if installation, operation and maintenance procedures are followed as outlined in this manual. If operating problems occur refer to the troubleshooting table below for common problems and solutions.

<b>Symptom</b>	<b>Probable Cause</b>	<b>Corrective Action</b>
<b>A. Vibration – Noise</b>	1. Loose foundation bolts	1. Tighten bolts, take care not to distort base.
	2. Bent shaft.	2. Inspect shaft, replace if bent.
	3. Binding rotating equipment.	3. Ensure pump rotates freely.
	4. Pumps too much liquid, head lower than rated.	4. Restrict discharge by partly closing valve.
	5. Cavitation on the suction side due to insufficient NPSH available.	5. Raise suction/liquid level or lower pump.
	6. Vibration in piping or at the pump assembly. Insufficient piping support.	6. Add additional pipe supports starting at pump discharge to eliminate vibration.
<b>B. No Discharge Flow</b>	1. Pump not primed – fluid too low.	1. Prime pump – raise liquid level.
	2. Speed too low.	2. Check voltage and frequency.
	3. Required discharge head too high.	3. Reduce head or increase speed. Take care not to overload motor.
	4. Impeller or volute is blocked.	4. Clear blockage.
	5. Suction port or screen is blocked.	5. Clear blockage.
	6. Wrong rotation direction.	6. Reverse any 2 leads on 3-phase motor.



Symptom	Probable Cause	Corrective Action
<b>C. Not Enough Discharge Flow</b>	1. Speed too low.	1. Increase pump speed.
	2. Air or gas in liquid.	2. Air or gas in liquid.
	3. Imposed discharge head too high.	3. Reduce head or increase speed. Take care not to overload motor.
	4. Impeller or volute is blocked.	4. Clear blockage.
	5. Not enough suction head for hot or volatile liquids.	5. Raise suction/liquid level.
	6. Wrong rotation direction.	6. Reverse any 2 leads on 3-phase motor.
	7. Clearance between impeller and suction cone too large.	7. Reset clearance.
	8. Insufficient NPSH available.	8. Raise suction/liquid level or lower pump.
<b>D. Speed too Low</b>	1. Incorrect wiring.	1. Check electrical connections of motor (is it receiving full voltage).
	2. Check motor.	2. Check motor.
<b>E. High Power Consumption</b>	1. Speed too high.	1. Lower pump speed.
	2. Pumps too much liquid, head lower than rating.	2. Restrict discharge by partly closing valve.
	3. Specific gravity or viscosity of liquid pumped higher than rated.	3. Reduce pump speed. Reduce liquid specific gravity or viscosity.
	4. Bent shaft.	4. Inspect shaft, replace if bent.
	5. Binding rotating element.	5. Ensure pump rotates freely.



Symptom	Probable Cause	Corrective Action
<b>F. Moisture detection light illuminated immediately after start-up</b>	1. Check that motor control wiring is not run through the same conduit as the power cable.	1. Control and power wires MUST be isolated.
	2. Possible residual moisture in seal chamber.	2. Let pump run for approx. 48 hours to see if moisture dissipates.
	3. If light stays on, pump must be removed to check for failure of seal, cable or cable cap assembly.	3. Repair any damaged parts.
	4. Drain oil from seal chamber.	4. Replace with new oil per motor manual.
<b>G. Moisture detection light stays illuminated but no problems found with seals or cable cap assembly</b>	1. Check that motor control wiring is not run through the same conduit as the power cable.	1. Control and power wires MUST be isolated. Contact Hayward Gordon ULC.



**IV. MAINTENANCE**

**A. Motor**

See Manufacturer's Instructions.

<b>Component</b>	<b>Maintenance Activity</b>	<b>Frequency</b>	<b>Amount &amp; Type of Lubricant</b>	<b>Reference</b>
Motor	<p>New motors are shipped with oil reservoir.</p> <p>Maintenance should be performed by qualified motor repair facility due to the water tight construction of the motor. Ceramic and other seals are easily damaged and special tools are required for service.</p> <p>Recommended lubricant is Shell Rotella 10 SAE 10W. For appropriate amount of lubricant, see Table 2-1 in Motor Manual</p>	As needed	N/A	Baldor-Reliance Motor Instruction Manual (MN414)





**V. SERVICE & REPAIR**

**A. Removing Pump**

1. Stop motor.
2. Close discharge valve.
3. Lock motor starter or disconnect motor cable at control panel.
4. Remove lifting chain from the hook and attach to lifting device.

(I) Quick Disconnect Style:

Steadily lift pump until disengaged from guide pipes. Lift pump above sump opening.

(II) Free Standing Pedestal Style:

Drain sump and disconnect discharge pipe from pump discharge flange. Remove pump pedestal hold down bolts or nuts. Lift pump above sump opening.

Lower pump securely on to skid or service pad.

**CAUTION!**

*Prior to any work on the pump or motor, the power supply to the unit must be disconnected in a safe manner, either by means of lock disconnect switch or by tripping fuses in the control panel.*

**B. Disassembly of Pump**

1. Refer to General Assembly drawings during dismantling.
2. Remove impeller screw (419 or A730) and impeller shroud (207) or disintegrator (206).
3. Remove bolts (b781), cutter bar plate (214), impeller (202) and impeller key (610).
4. Remove impeller hub (205) and key.
5. Remove bolts (A727), flat washer (C746) and volute casing (A705) from motor/ motor adapter plate assembly.
6. Remove motor gasket (452).

**C. Disassembly of Motor**

Refer to Motor Instruction Manual.



**D. Parts Inspection**

Impeller:

If the impeller shows excessive wear due to abrasion or corrosion and performance cannot be restored, it must be replaced.

Motor:

Follow motor instructions regarding motor inspection.

All parts must be clean before reassembly. This is especially important at retaining ring grooves, threads, gasket surfaces and bearing lubrication areas. Remove burrs with fine emery cloth especially on shaft surface.

**E. Reassembly of Motor**

Refer to Motor Instruction Manual.

**F. Reassembly of Pump**

All bolts used on dynamically loaded components, i.e., pump impellers MUST be tightened to the torque values shown below. Over tightening may cause premature fatigue failure. Figures are based on dry (non-lubricated) bolts.

*Table V-1: Recommended Bolt Torque Values*

<b>Recommended Tightening Torque</b>		
<b>All Values in ft./lbs.</b>		
<b>Bolt Diameter (in.)</b>	<b>Std. bolts grades 0-3 Stainless Steel Alloy 20 &amp; Hastelloy B &amp; C</b>	<b>Grades 5-8 All socket head capscrews</b>
3/8"	25	36
1/2"	55	85
5/8"	95	165
3/4"	165	275
7/8"	190	470
1"	260	700
1 1/4"	525	1200



1. Refer to General Assembly drawings during re-assembly.
2. Install motor on volute casing (201) and tighten motor bolts (A727) with flat washer (C746).
3. Install shims (A451) (as required- see section G for clearance details) in the impeller (202) or shaft adapter (403).
4. Install impeller (202) and impeller key (A408) and check the gap between the volute (201) and impeller. (See section G for clearance details).
5. Install cutter bar plate (214), O-ring (C506) and cutter bar bolts (B781).
6. Install impeller shroud (413) or disintegrator (206) and impeller screw (419) with lockwasher (D746).

*DO NOT OVER-TIGHTEN BOLTS.*

7. Put hand into volute suction and check for free rotation of impeller/shaft by hand.

(I) IMPELLER CLEARANCES

1. Install impeller (202). There should be a measured gap of 0.008” – 0.015” between the back of the impeller and volute casing (A705).
2. Use metal shim set (A451) if required. This should be located inside the impeller hub (205) between the hub and motor shaft.
3. Measure the front impeller (202) clearance between the impeller and cutter bar plate (214). The clearance range is set out in the following chart.
4. Use metal shim set (B451) as required to adjust back clearance.

*Table V-2: Impeller Clearances*

<b>Pump Model</b>	<b>Front Clearance</b>	<b>Back Clearance</b>
CHOPX 3A/B	0.010” – 0.014”	0.008” – 0.012”
CHOPX 4A/B	0.010” – 0.014”	0.008” – 0.012”
CHOPX 5B	0.015” – 0.020”	0.008” – 0.012”
CHOPX 8LB	0.015” – 0.020”	0.010” – 0.015”
CHOPX 8RB	0.025” – 0.030”	0.010” – 0.015”
CHOPX 8B	0.025” – 0.030”	0.010” – 0.015”
CHOPX 10B	0.025” – 0.030”	0.010” – 0.015”
CHOPX 12B	0.025” – 0.030”	0.010” – 0.015”



**G. Parts Inventory Guide**

For parts inventory refer to General Assembly drawing and parts lists. The recommended spare parts are:

*Table V-2: Recommended Spare Parts*

<b>Item</b>	<b>Description</b>
202	Impeller (*L)
214	Cutter Intake (*L)
A501	Inboard Bearing
B501	Outboard Bearing
C506	O-ring Intake Plate
A525	Volute Casing Gasket
A540	Upper Mechanical Seal Assembly
B540	Lower Mechanical Seal Assembly

(\*L) = Long Term Spares

**H. Parts Ordering**

The following information should be available for prompt processing of parts orders:

1. The serial number of the pump (on nameplate)
2. The part name (on sectional drawing)
3. The part number (on sectional drawing)
4. The quantity of parts needed

Hayward Gordon ULC may supply an interchangeable part that is not identical in appearance or symbol. This is done only if the part has been improved. Examine parts carefully upon their receipt.

If an impeller is ordered, specify diameter across blade tips to be sure there has been no further trim on diameter than shown on Hayward Gordon records.

If you do have to trim an impeller, be sure to re-balance after machining.

If motor or motor parts are ordered, specify name of drive manufacturer and all other data on driver nameplate.



## **VI. DRAWINGS**

See following pages for general assembly drawings and parts lists.



## VII. MOTOR INFORMATION

### A. Electrical Connections

#### **CAUTION!**

*Make sure that power supply to control panel is the same as on the motor nameplate.*

*Power and control cable must be continuous run from motor to control panel outside the sump to prevent damage to the motor. **DO NOT** splice or use junction box.*

#### (I) CONTROL PANEL

To assure non-voidance of warranty and proper protection of the motor, the control panel must, as a minimum, contain the following components:

- Thermal Protection System – see Motor Manual
- Moisture Detection System – see Motor Manual

In addition to the above, the control panel shall contain the following components:

- Isolation Switch, lockable one preferred.
- Slow Trip Fuses or Circuit Breakers in each incoming phase.
- Lightning Arrestor on each incoming phase, if any possibility of lightning damage exists.
- Start Switch.
- Seal Failure Alarm Light.

Follow motor Wiring Diagram and Instructions for proper component selection and connections.

- Level Switches – for high-level alarm a floating ball type is recommended as most reliable switch.
- Level Control – “ON” and “OFF” levels to be set in such a manner as to avoid switching pump on more than 10 times per hour to prevent any possible damage to motor.

Recommended additional controls:

- Alarm system for high sump level, preferably on separate power supply.
- Hand-off automatic switch.
- Terminals for level switches.
- Single phase protection.